

Recommended mounting hole

Single o-ring

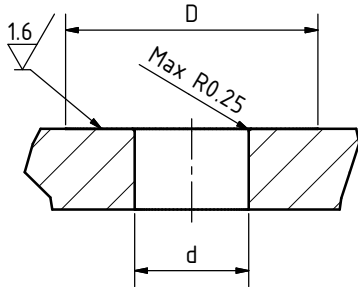

Thread size	Hole size (d)	Tolerance	Surface size (D)
3/8"	ø 0.374", 9.5 mm	+/- 0.1	ø 0.984", 25.0 mm
7/16"	ø 0.445", 11.3 mm	+/- 0.1	ø 0.984", 25.0 mm
1/2"	ø 0.534", 12.8 mm	+/- 0.1	ø 0.984", 25.0 mm
5/8"	ø 0.629", 16.0 mm	+/- 0.1	ø 1.181", 30.0 mm
3/4"	ø 0.807", 20.5 mm	+/- 0.1	ø 1.574", 40.0 mm
1"	ø 1.024", 26.0 mm	+/- 0.1	ø 1.965", 50.0 mm
7/8"	ø 0.886", 22.5 mm	+/- 0.1	ø 1.574", 40.0 mm
1 1/2"	ø 1.516", 38.5 mm	+/- 0.1	ø 2.165", 55.0 mm

Double o-ring

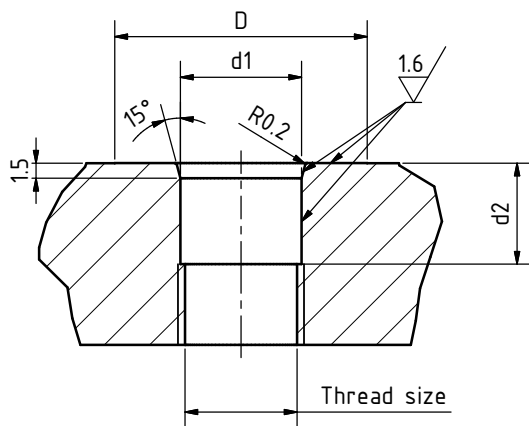

Thread size	Hole size (d1)	Tolerance	Hole depth (d2)	Tolerance
7/16"	ø 0.47", ø12 mm	H8	ø 0.41", 10.5 mm	+/- 0.1
1/2"	ø 0.55", ø14 mm	H8	ø 0.52", 13.2 mm	+/- 0.1
5/8"	ø 0.685", ø17,4 mm	H8	ø 0.36", 9.2mm	+/- 0.1